

**"Apollo"® SmartPress**  
VSH technology

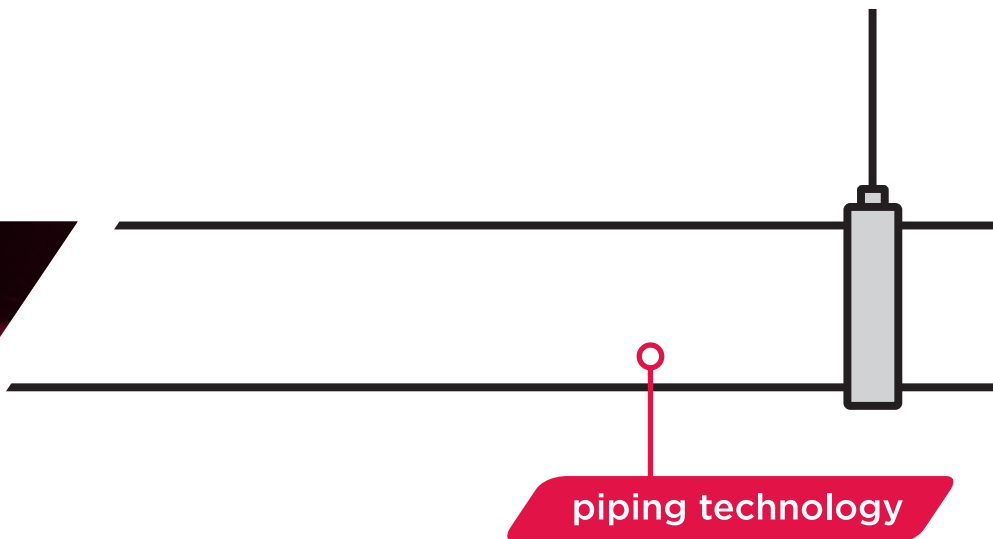

Aalberts integrated piping systems

don't just buy  
products,  
buy solutions.



# we are Aalberts integrated piping systems

Aalberts integrated piping systems engineers the most advanced integrated piping systems for the distribution and control of liquids and gases for key verticals, like industrial, utilities, commercial and residential. We offer fully integrated piping systems in valve, connection, fastening and piping technology. We work hand-in-hand with our customers to create the perfect integrated piping system, that meets their requirements. Our piping systems are easy to specify, install, control and maintain, saving important preparation and installation time. We meet the highest quality and industry standards needed in the selected verticals. We are the only business that truly offers its customers a single sourced and complete integrated piping solution, each and every time.

**Don't just buy products, buy solutions.**

### our mission

With our integrated piping systems, supported by our unique Digital Design Service, we ensure that you will always get the best and easiest solution for the installation of an integrated piping system. From the moment that your plan is designed, you can get advice on complete and tailored solutions. With our Revit Plug-in you have digital access to the complete product offering within Aalberts integrated piping systems. This information is always accessible and up to date, allowing the design of an optimal and economically attractive installation that will meet all your demands. So whether the task is project conception, installation, or on-going maintenance, we are the company that truly delivers a complete system and service offering. Our know-how, our can-do attitude, and our relentless innovation come as standard. We will sweat the small stuff in our quest to find the perfect solutions, even if we have to invent them.

**This is how we deliver excellence.**

### our way of working

We operate from various regions around the globe: America, United Kingdom, Middle East, Asia Pacific and Europe. As we have multiple locations in many countries, we are always close to our customers. More than 3500 mission critical employees are persistent to offer the best integrated piping system. They work on our products, solutions and services every day. No matter how big the opportunity is, when we say we've got this, we won't let go until there is nothing left to learn. We improve ourselves by exchanging knowledge and experience to stay ahead of our competitors.

**Good is never good enough.**

With our sustainable spirit we contribute to circularity every single day. This belief is strongly linked to the way we do business. Rethink, reduce and recycle. We are entrepreneurial and take ownership in everything we do. We are convinced that self-development and diversity is essential.

**The Aalberts way, winning with people.**

the strength of Aalberts integrated piping systems

- the perfect solution for every project
- smart, fast and efficient installation
- valuable advice from the drawing board to delivery
- a very wide product range

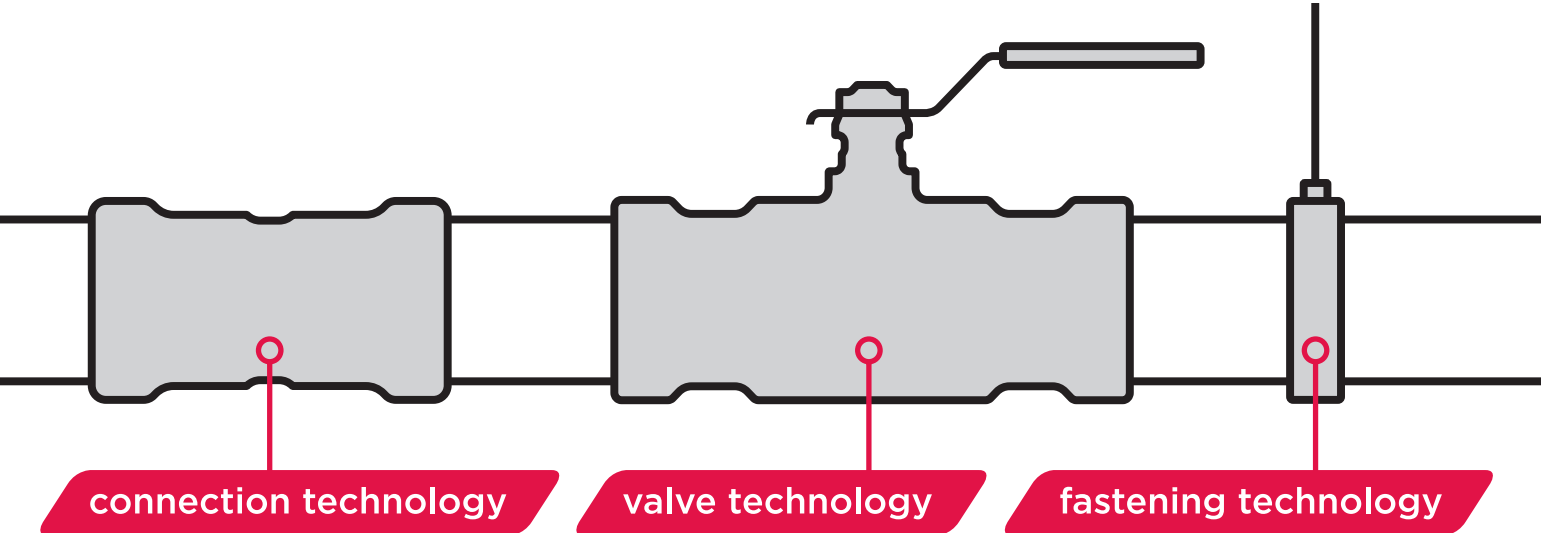

For more information about Aalberts integrated piping systems, go to [aalberts-ips.us](http://aalberts-ips.us)

# Apollo® SmartPress, the smartest press system for stainless piping

Ultra-modern manufacturing technology meets proven product design expertise with the all new Apollo® SmartPress fitting and valve product offering produced from AISI 316 stainless steel alloy. Apollo® SmartPress is an innovative IPS press connection system designed for joining ½” through 2” ASTM A312 stainless steel in combination with schedule 5S and 10S piping systems (type 304/304L or 316/316L). Whether you are installing a commercial potable water system or an industrial utilities process application, Apollo® SmartPress is made to withstand the harshest of environments.

## 3x safety assurance

All Apollo® SmartPress fittings and valves come equipped with VSH technology 3x safety assurance. These smart safety features reduce installation error, generate time cost savings and above all else, ensure job site safety.

### 1. visual materials identification

The color-coded Visu-Control® foil indicates the connection size and sealing element compound within the press fitting or valve to reduce the risk of misapplication – yellow indicates HNBR, green: EPDM, and blue: FKM.

### 2. visual press identification

The Visu-Control® foil splits for easy removal after press completion; this ensures that unpressed connections stand out and are easily recognizable prior to system pressurization.

### 3. mechanical press identification

Built-in Leak Before Press® technology allows media to slowly leak for easy detection of unpressed connections during initial pressure testing.





### smart sealing elements

All Apollo® SmartPress products feature a patented 'smart' sealing element with a unique geometry that provides a dual function grip, it allows for immediate tactile detection upon insertion while also keeping the fitting firmly in place on the pipe for optimal alignment and convenient installation. Additionally, Apollo® SmartPress' advanced sealing technology includes built-in Leak Before Press® technology and is manufactured and assembled using a silicone-free process.

convenient installation,  
time savings and safety are  
the top priorities

- one material, maximum efficiency (AISI 316)
- wide range of ½" through 2" fittings and valves
- up to 500 psi operating pressure
- temperatures ranging from -31°F to +446°F
- ultra-modern silicone-free production process
- patented 'smart' sealing element technology
- Leak Before Press® technology
- Visu-Control® foil technology
- color-coded materials and size
- visual press indication
- patented pre-marked insertion depths





# Apollo® SmartPress application coverage

The Apollo® SmartPress product range consists of V-profile press fittings and valves fitted with patented sealing elements for a guaranteed safe, leak-tight and lasting connection. The Apollo® SmartPress system offers a complete solution with maximum coverage of applications requiring HNBR, EPDM, or FKM sealing elements.

For each sealing element variation, available Apollo® SmartPress fitting configurations include: couplings, caps, elbows, thread adapters, tees, reducers, flange adapters and unions; Apollo® SmartPress valve configurations include optimized single-piece FullFlow ball valves and 3-piece ball valves (stem extensions and press x thread end-connections available).



## Apollo® SmartPress HNBR characteristics

- yellow Visu-Control® foil
- yellow bag & box labels
- yellow marked, black HNBR sealing elements (lubricant-free)

### temperature range

- -22°F to +212°F
- +230°F max (short-term)

### max. pressure

- 500 psi max for 10S
- 300 psi max for 5S

### most suitable for

potable water, fire sprinkler, heating & cooling, compressed air, hydrocarbons, instrument air, mineral & vegetable oil, engine & transmission oil, fuel oil, vacuum, circulation pipes, industrial gases.



## Apollo® SmartPress EPDM characteristics

- green Visu-Control® foil
- green bag & box labels
- black EPDM sealing elements (lubricant-free)

### temperature range

- -31°F to +275°F
- +302°F max (short-term)

### max. pressure

- 500 psi max for 10S
- 300 psi max for 5S

### most suitable for

potable water, fire sprinkler, heating & cooling, compressed air (synthetic or dry), instrument air, vacuum, circulation pipes, low pressure steam (max 230°F).



## Apollo® SmartPress FKM characteristics

- blue Visu-Control® foil
- blue bag & box labels
- blue FKM sealing elements (ozone-resistant)

### temperature range

- -4°F to +392°F
- +446°F max (short-term)

### max. pressure

- 500 psi max for 10S
- 300 psi max for 5S

### most suitable for

industrial design (ozone-resistant), solar installations, compressed air, lubricants, mineral & vegetable oil, fuel oil, industrial gases, hydrocarbons, vacuum.

# Apollo® SmartPress fittings

## prioritize safety, reduce error costs

- one material, maximum efficiency (AISI 316)
- up to 500 psi operating pressure
- wide coverage of industrial and commercial applications
- patented HNBR, EPDM and FKM sealing elements
- silicone-free production process
- VSH technology 3x safety assurance:
  1. visual identification of material and size
  2. visual identification of unpressed connections
  3. mechanical identification of unpressed connections
- 10-year limited warranty
- BIM ready

### clear laser marking

All fittings come laser etched with the Apollo® SmartPress product logo, size, sealing element (H, E, F), traceability code, country of origin, and applicable certifications.

### pre-marked insertion depths

Factory marked insertion depth line on street-end fittings save time and promote confident connections.



### ground-joint unions

Easily connect and disconnect where breaks in the system are needed with Apollo® SmartPress unions. Precisely machined metal-to-metal union seals eliminate loose parts and prevent misalignment.

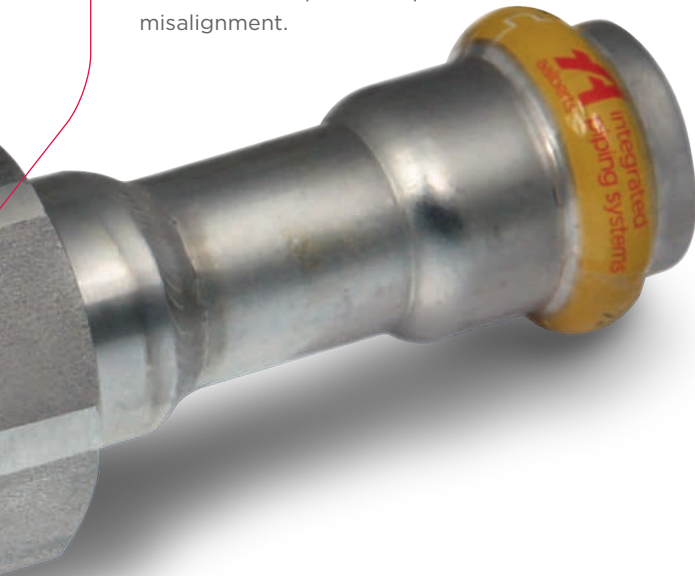

### floating flange options

Apollo SmartPress® Van Stone flange adapter's floating 2-piece design allows for easy bolt-hole alignment with stationary surfaces.



### Visu-Control® foil

The color-coded VCF visual safety feature reduces the risk of misapplication (material, size) and provides breakaway press confirmation, ensuring unpressed connections stand out prior to system pressurization.



### Leak Before Press®

The built-in LBP mechanical safety feature allows for easy identification of unpressed connections during initial pressure testing.

### smart sealing elements

Patented design provides tactile detection of sealing element presence, optimal pipe grip, and Leak Before Press® functionality.

# Apollo® SmartPress valves

## Apollo® SmartPress FullFlow valve

### patented design

The Apollo® SmartPress FullFlow ball valve is maintenance free and includes a patented spring construction for optimal ball sealing and a long life in harsh environments.

### compact FullFlow design

Meet modern HVAC system requirements with the compact single-piece FullFlow design that makes for easy insulation work in tight spaces.

### smart handle inserts

Reversible color-coded handle inserts make application identification simple and easy (red: hot, blue: cold).

### insulatable stem

Optimal insulation possibilities because all Apollo® SmartPress FullFlow ball valves come with a stem guide that does not rotate when the valve is operated.

### ergonomic handle

Reversible stainless steel handle with composite outer-layer remains cool in high-temperature installations and can be easily mounted in either direction without using any tools.

### flushing ball

The flushing ball seal helps mitigate bacterial growth and balances the ball and cavity pressure, which is critical in freezing conditions to prevent ball cracking.

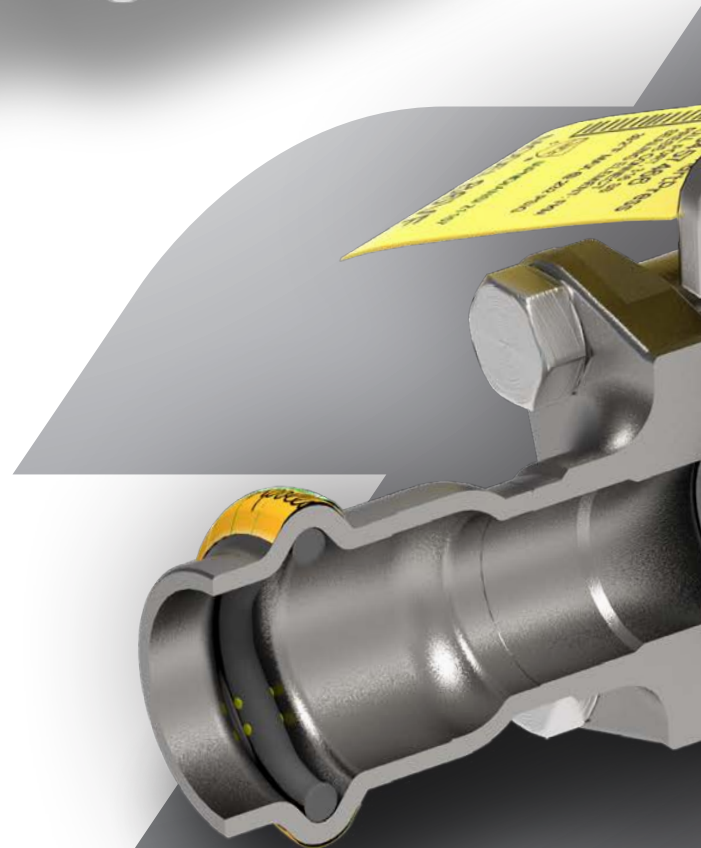

## Apollo® SmartPress valves key features

- 100% full port flow
- blow-out proof stem
- one material for maximum corrosion protection (stainless steel AISI 316)
- The high-precision Apollo® SmartPress press profile (V/ASM-profile) ensures fast, perfect connections
- color coded Visu-Control® foil technology indicates sealing element, size, and breakaway press confirmation
- Leak Before Press® function allows unpressed connections to be quickly detected
- 5-year limited warranty
- BIM ready



## Apollo® SmartPress 3-piece ball valve

### ergonomic design

The easy to maintain 3-piece valve enables in-line repair with a swing-down design.

### locking handle

The signature "Apollo" yellow stainless steel handle standardizes on a lockable, latch-lock, handle. Additional options and configurations available.

### ISO 5211 mounting pad

The standardized mounting pad provides easy mounting for valve actuation.

### RPTFE seats

Our in house manufactured, high quality RPTFE ball seats ensure a smooth opening and closing of the valve for optimal ball sealing and a long life.



potable water



heating



cooling



compressed air



steam



solar



sprinkler



vacuum

# Apollo® SmartPress general applications

## potable water

With a Apollo® SmartPress system, you can be confident of compliance with all applicable standards for open and closed water and potable water systems. All system components are available in stainless steel and are fully corrosion resistant, even when exposed to demineralised or distilled water.

## heating and cooling

Apollo® SmartPress is the best solution for heating and cooling systems. The products undergo the most stringent tests during the production process and are absolutely leak-proof. Thanks to their design and the production process, the fittings have smooth interior profiles. As a result, they have very low flow resistance and low noise level. Additionally, the sleek and low-profile design of Apollo® SmartPress fittings and valves make insulation work seamless and easy.

## steam

Apollo® SmartPress Stainless is particularly suitable for low-pressure steam piping systems. Steam up to 230°F can even be installed with Apollo® SmartPress Stainless using the standard EPDM sealing element.

## compressed air

Apollo® SmartPress is ideal for compressed air installations. Different types of sealing elements are used depending on the oil content. When the compressed air contains mineral or vegetable oil, HNBR or FKM sealing elements must be used. EPDM sealing elements can only be used for synthetic oil or dry compressed air.

## solar

The Apollo® SmartPress system is equipped with EPDM sealing elements that can withstand high temperatures up to 275°F with allowable short-term spikes up to 302°F. If even higher temperatures are involved, choose Apollo® SmartPress products with special FKM sealing elements that can withstand temperatures up to 392°F with allowable short-term spikes up to 446°F.

## sprinkler

Our Apollo® SmartPress system is certified for sprinkler and low pressure water mist installations and is suitable for fixed sprinkler installations.

Application approval dependent on suitability of selected sealing element's performance characteristics and limitations. For more information on Apollo® SmartPress approved applications, please refer to our technical documentation listed at

[aalberts-ips.us/product-lines/apollo-smartpress](http://aalberts-ips.us/product-lines/apollo-smartpress)

# Aalberts ips field services



At Aalberts integrated piping systems, we understand that good is never good enough and that we win with people and solutions, not just products. For these reasons, we have developed a team of dedicated plumbing and mechanical systems experts to provide field support throughout each step of the installation and operation process. Aalberts ips field services team provides a wide variety of solutions and training to support distribution, engineering, and ultimately, the end-user. Our mission is to promote safe and quality installation of our products in your system by providing hands-on value added expertise from preconstruction, to completion and beyond.

## preconstruction

- pre-project installation training at project site or fabrication shop
- in-depth review of product and tool installation, operation, and inspection
- proof of training logs available to ensure up-to-date product knowledge

## construction

- periodic job site visits to review and assist installation process when needed
- on site assessment and trouble shooting throughout duration of the project
- if necessary, provide repair and maintenance training for the end-user

## project completion

- pre-commissioning project walk throughs and advisement
- installation and quality assurance inspections
- system servicing and product inquiries

## Aalberts ips field service advantages

- field experts that fit your system
- increase installation efficiency and reinforce safe and best practices with on-site training and field support
- trouble shooting assistance beyond project life
- on-time project completion to help you meet budget

# are you facing the following challenges with your projects?

- increased material and labor costs
- material estimating for future projects
- piping interferences and trade collisions
- material back-orders
- compressed delivery schedules
- long lead-times
- space limitations
- unnecessary material waste



## Aalberts ips design service

To accompany our vast portfolio of piping products, we offer Aalberts ips design service to ensure an efficient build from start to finish because we understand that every project presents its own unique set of requirements and challenges.

Our work method is simple: using your concept plan, Aalberts ips design service will look for the most optimal and economic way to achieve your project requirements. That plan is then adjusted until you, and your client, are completely satisfied.



## Aalberts ips Revit plug-in

Aalberts integrated piping systems has developed a plug-in for Autodesk Revit with which users can easily and clearly select Revit families and load them into projects. In addition to a library function, the plugin contains a number of useful tools that simplify the modeling of piping systems within Autodesk Revit.

- design complex piping systems faster with 15,000+ Aalberts ips products
- structured data based on ETIM-MC standards
- optimized pipe types and routing preferences based on application, approval, and standards
- selection and modeling tools that simplify workflow and increase productivity
- compatible with latest Autodesk Revit versions (2019 through current)





# Aalberts ips design service

## Aalberts ips design service advantages

- detailed material takeoffs
- competitive cost comparisons
- custom equipment detailing
- 3D coordination drawings
- pipe movement design
- system fabrication drawings
- efficient design-build with Aalberts ips Revit plug-in

### coordination drawings

- 3D shop drawings for optimized coordination
- identify building interferences and trade conflicts
- get an early start with our preliminary materials lists to ensure accurate lead-times for on-time delivery of products

### equipment detailing

- equipment drawings and material lists detailed using Aalberts ips products
- custom CAD/BIM model equipment connection detail
- installation assembly schematics

### material takeoffs

- itemized lists of Aalberts ips fittings, valves and piping accessories for projects
- includes project labor and materials estimates for system design

### pipe movement design

- thermal movement calculations
- identifying pipe anchor and guide locations with load calculations
- custom thermal expansion and seismic joints

### cost comparisons

- compare Aalberts ips products against alternative piping methods
- evaluate competitive materials cost, labor cost and installation times

### fabrication drawings

- 3D MER tagged fabrication Formatting
- fitting and valve accessory BOMs
- piping spool lists

more information?

---

For a complete and up-to-date product range and our additional services, visit:  
[aalberts-ips.us](https://aalberts-ips.us)

Would you like to make an appointment to meet an account manager in your region or receive advice and support from one of our experts?

Please contact:

**Aalberts integrated piping systems customer service**

**704.841.6000 (US)**

**905.851.9494 (CAN)**

